

DEPARTMENT OF THE ARMY TECHNICAL MANUAL

OPERATOR'S MANUAL

MILLING MACHINE, HORIZONTAL, UNIVERSAL,
FLOOR MOUNTING, 49 x 10 WORKING SURFACE,
28-INCH LONGITUDINAL TRAVEL, 10-INCH CROSS
TRAVEL, 16 1/2-INCH VERTICAL TRAVEL,
5-HORSEPOWER, 208-VOLTS, 60-CYCLE, 3-PHASE
(GREAVES MACHINE TOOL DIV., FAY AND EGAN CO.
MODELS 2XH AND 2H) (FSN 3417-240-1303)



HEADQUARTERS, DEPARTMENT OF THE ARMY

AUGUST 1966

CHANGE }
No. 1 }

HEADQUARTERS
DEPARTMENT OF THE ARMY
Washington, D.C., 9 May 1973

**Operator's Manual
MILLING MACHINE, HORIZONTAL, UNIVERSAL,
FLOOR MOUNTING, 49 X 10 WORKING SURFACE,
28-INCH LONGITUDINAL TRAVEL, 10-INCH CROSS
TRAVEL, 16-1/2 INCH VERTICAL TRAVEL,
5-HORSEPOWER, 208-VOLTS, 60-CYCLE,
3-PHASE (GREAVES MACHINE TOOL
DIV., FAY AND EGAN CO. MODELS
2 X H AND 2H) (FSN 3417-240-1303)**

TM 9-3417-209-10, 21 August 1966, is changed as follows:

Table 1 Components of the End Item

Page 8. Add the following paragraphs:

11. Report of Equipment Publication Improvements

The reporting of errors, omissions, and recommendations for improving this publication by the individual user is encouraged. Reports should be submitted on DA Form 2028 (Recommended Changes to Publications) and forwarded direct to Commander, US Army Weapons Command, ATTN: AMSWE-MAS-SP, Rock Island, IL 61201.

12. Components of the End Item

Parts included with the end item and considered as components of the end item configuration are listed in the following table:

Components	Part No	(FSCM)
ADAPTER, CHUCK:	55238	(26118)
ARBOR, SPINDLE:	36127	(26118)
ARBOR, SPINDLE:	36130	(26118)
ARBOR, SPINDLE:	36162	(26118)
ARBOR, SPINDLE:	36166	(26118)
ATTACHMENT, MILLING:	113	(26118)
ATTACHMENT, SLOTTING:	115	(26118)
CHUCK, MACHINE:	3684	(26118)
COLLET SET. c/o 22 collets sizes 1/8 hole dia to 7/8 hole dia	55165	(26118)
DRAWBAR, ADAPTER:	680	(26118)
HEAD DRIVING:	DSR10	(26118)
NUT, LOCKING:	146	(26118)
TABLE, ROTARY:	R-12	(26118)
VICE, TABLE:	1026	(26118)
WRENCH, SPANNER:	sp	(26118)

**APPENDIX A
BASIC ISSUE ITEMS LIST
AND
ITEMS TROOP INSTALLED OR AUTHORIZED LIST**

Section I. INTRODUCTION

1. Scope

This appendix lists basic issue items and items troop installed or authorized required by the crew/operator for operation of the Universal Horizontal Milling Machine.

2. General

This Basic Issue Items List and Items Troop Installed or Authorized List is divided into the following sections:

a. Basic Issue Items List-Section II. A list in alphabetical sequence of items which are furnished with, and must be turned in with, the end item.

b. Items Troop Installed or Authorized List. Not applicable.

3. Explanation of Columns

The following provides an explanation of columns found in the tabular listings:

a. Federal Stock Number. Indicates the Federal stock number assigned to the item and will be used for requisitioning purposes.

b. Description. Indicates the Federal item name and a minimum description required to identify the item. The last line indicates the reference number followed by the applicable Federal Supply Code for Manufacturer (FSCM) in parentheses. The FSCM is used as an element in item identification to designate manufacturer

or distributor or Government agency, etc., and is identified in SB 70842.

Items that are included in kits and sets and listed below the name of the kit or set with quantity of each item in the kit or set indicated in front of the item name.

c. Unit of Measure (U/M). Indicates the standard or basic quantity by which the listed item is used in performing the actual maintenance function. This measure is expressed by a two-character alphabetical abbreviation, e.g., ea, in., pr, etc., and is the basis used to indicate quantities. When the unit of measure differs from the unit of issue, the lowest unit of issue that will satisfy the required units of measure will be requisitioned.

d. Quantity Furnished with Equipment (Basic Issue Items Only). Indicates the quantity of the item furnished with the equipment.

e. Quantity Authorized (Items Troop Installed or Authorized Only). Indicates the quantity authorized to be used with the equipment.

f. Illustration (Basic Issue Items Only). This column is divided as follows:

(1) *Figure Number.* Indicates the figure number of the illustration in which the item is shown.

(2) *Item Number.* Indicates the item number used to identify each item called out in the illustration.

Section II. BASIC ISSUE ITEMS

(1) Federal stock No.	(2) Description	(3) Unit of of meas	(4) Qty furn with equip	(5) Illustration	
				(a) Fig. No.	(b) Item No.
5120-187-7134	WRENCH, OPEN END, FIXED. dble hd type, 1-1/16 and 1-1/4 wrench opngs, 15 deg angle of hd, hd thk 1/2 in , 11-3/4 lg o/a	EA	1	D	7
5120-277-1255	WRENCH, OPEN END, FIXED sgle hd type, 25/32 wrench opng, 15 deg angle of hd, hd thk 7/16 in, 7-3/8 lg o/a	EA	1	D	8
5120-288-8702	WRENCH, OPEN END, FIXED: sgle hd type, 1-3/4 wrench opng, 15 deg, hd thk 5/16 in , 12-1/4 lg o/a	EA	1	D	9
5120-224-2535	WRENCH, SOCKET. sgle socket offset type, 90 deg offset hex socket, 1-1/4 wrench opng, 2-1/2 offset, 11 lg o/a	EA	1	D	11

By Order of the Secretary of the Army:

CREIGHTON W. ABRAMS
General, United States Army
Chief of Staff

Official:

VERNE L. BOWERS
Major General, United States Army
The Adjutant General

Distribution:

Active Army

DCSLOG (3)	Armies (3) except
CNGB (1)	Seventh & Eighth USA (5)
TSG (1)	Corps (2)
COE (5)	USAECFB (2)
Dir of Trans(1)	AD (3)
ACSC-E (1)	Arsenals(2)
CONARC (2)	FLDMS (2) except
AMC (5)	Ft Knox (10)
WECOM (10)	USASA 4th Fld Sta (1)
MUCOM (2)	Units org under fol TOE:-2 ea.
AVSCOM (2)	11-15
ARADCOM (2)	11-17
ARADCOM Rgn (2)	11-38
OS Maj Comd (2)	11-587
LOGCOMD (2)	

ARNVG & USAR None.

For explanation of abbreviations used, see AR 310-50.

☆ U S. GOVERNMENT PRINTING OFFICE: 1973-769618/748

TECHNICAL MANUAL }
No. 9-3417-209-10 }

HEADQUARTERS
DEPARTMENT OF THE ARMY
WASHINGTON, D.C., 24 August 1966

Operator's Manual

**MILLING MACHINE, HORIZONTAL, UNIVERSAL, FLOOR MOUNTING,
49 x 10 WORKING SURFACE, 28-INCH LONGITUDINAL TRAVEL,
10-INCH CROSS TRAVEL, 16 1/2-INCH VERTICAL TRAVEL,
5-HORSEPOWER, 208-VOLTS, 60-CYCLE, 3-PHASE
(GREAVES MACHINE TOOL DIV., FAY & EGAN COMPANY MODELS 2XH & 2H)
(FSN 3417-240-1303)**

	Page
Section I. Specifications	2
II. Installation.....	3
III. Operation and Set-up.....	5
IV. Maintenance-Lubrication	6
Appendix A. Basic Issue Items List	9

SECTION I
SPECIFICATIONS

1. 2XH

Table (available as an extra working surface and size overall).....60 1/4" x 12"
 T-Slots - number and width.....5 slots 11/16 wide
 T-Slots - center distance...2-1/4"
 Swivels (universal only)....45°
 Feed Range
 Longitudinal feedtable 35"
 Cross Feed.....10"
 Vertical Feed.....19"
 Distance - Center line spindle to top of table.....maximum 19"; minimum 0"
 Width
 Column to brace26 1/2"
 Column to inside arbor support.....23 1/4"
 Spindle
 Heat Treated Chrome nickel steel, national standard taper hold No. 50.
 Diameter of nose.....5 1/6"
 Size of hole through spindle1 1/8"
 Speeds
 Number18
 Range25-1250 rpm
 Feeds
 Number18

Range - inches per minute.....1/2" to 30"
 Bearings
 Spindle and drive shafts...Timken
 Rapid Traverse
 All directions with directional control100" per min.
 Drive
 Silent multiple V-belt from motor in base,
 Pulley speed.....720 rpm
 Motor: hp, rpm7.5-1750
 Lubrication
 Speed and feed gearing ...Forced positive lubrication (pumps)
 Pressure lubrication to table saddle, slides and screwsPlunger pump from reservoir
 Coolant system.....7 1/2 gal. (Coolant Pump)
 Arbor Support
 Regular equipment single
 Overarm support with bronze bushing2 1/8" dia. hole

2. 2H

Same as 2XH Except:
 Working surface and overall size54 1/4" x 12"
 Cross feed.....12"
 Vertical feed18"
 Motor: hp, rpm5-1750

SECTION II

INSTALLATION

3. Uncrating and Mounting

Remove the bolts which fasten the machine to the skids. Adjust the overarm to a position convenient to accommodate a rope sling. Tighten the overarm clamp nuts (1), figure A and then lift the machine from the skids using a rope sling. Use care to avoid damaging the appurtenances especially if your machine is equipped with a toolmakers overarm. Be sure to place the machine on a level surface. The foundation you provide for the machine should be as solid as possible, reinforced concrete of 6-inch or more thickness is recommended. If the machine must be located on a wooden floor or balcony it should be placed directly over a supporting beam or girder.

Clean the entire machine and remove the antirust solution thoroughly. Oil all ways with a clean

machine oil. Make certain there is no grit on the ways.

Level the machine with a "precision level" set in both directions on the table. Drive wedges under the four corners of the base until a level reading is obtained in both directions. A carpenter's level or combination-square level is not accurate enough. The precision level should read to 10 seconds per graduation. (.0005" per foot)

When the machine has been leveled, drive additional wedges around the base to evenly distribute the weight. Check to see that the leveling has not been impaired.

After the machine has been in operation, check the level again. Continue periodic checks thereafter to maintain the accuracy.

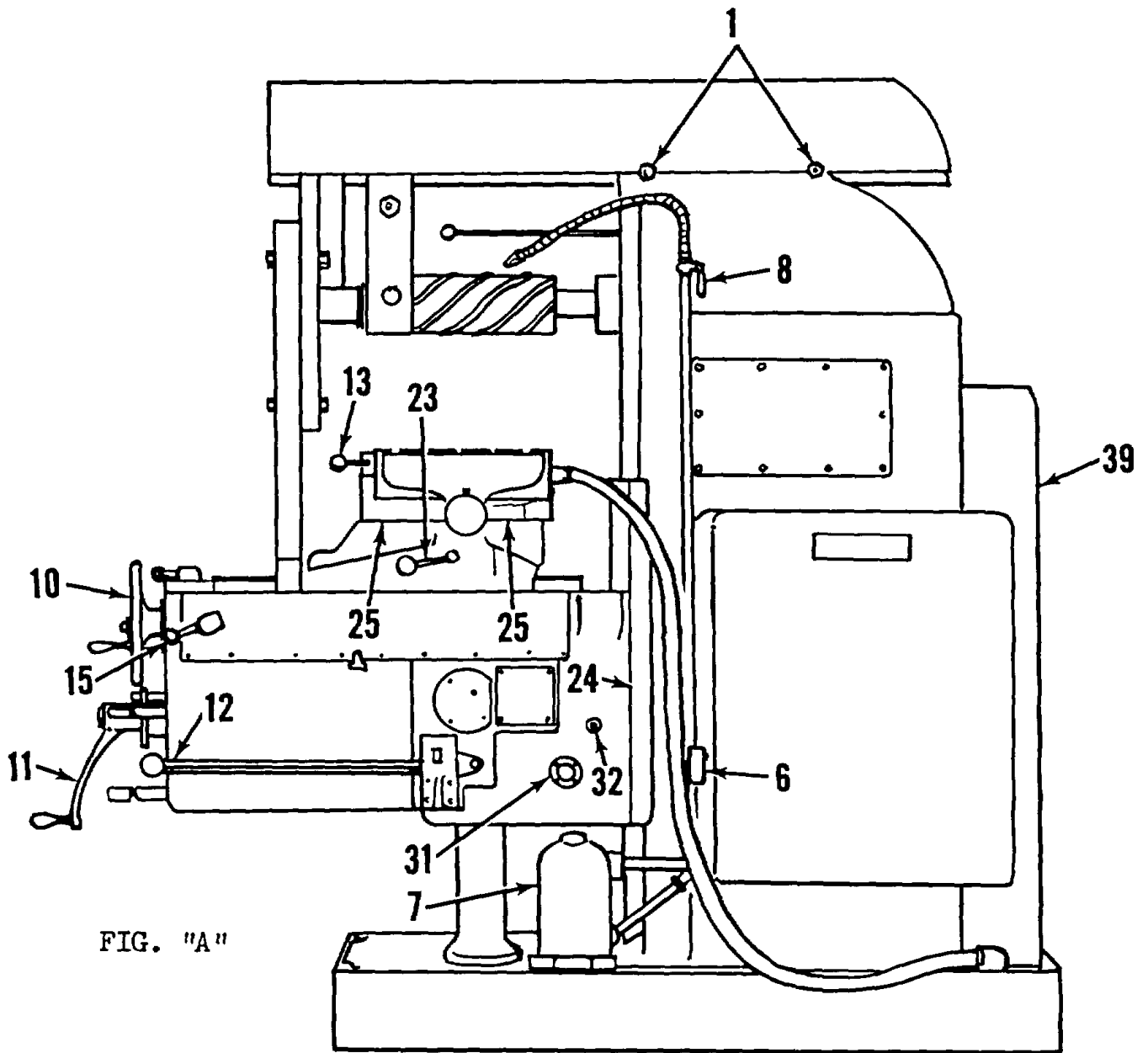

FIG. "A"

Figure A.

SECTION III

OPERATION AND SET-UP

4. Control

a. *Electric Controls.* The pendant control (2, fig. B) consists of a master start button for all motors, a "Forward-Reverse" button for the 712 hp spindle motor and a master stop toggle switch for all motors.

A separate spindle control switch (5, figs. B and C) located on the left hand side of the column has three separate positions; that is JOG STOP RUN. Moving the

lever toward the machine is the RUN position and STOP is the central position. JOGGING position is to the left and is used as an aid to shift the speed gearing.

b. *Coolant Pump Control.* An "ON-OFF" push button station seen in (6), figure A controls operation of the coolant pump (7). A valve (8) controls the flow of coolant from the pump. The pump may run with this valve closed with no injurious effects since the pump itself is a centrifugal type.

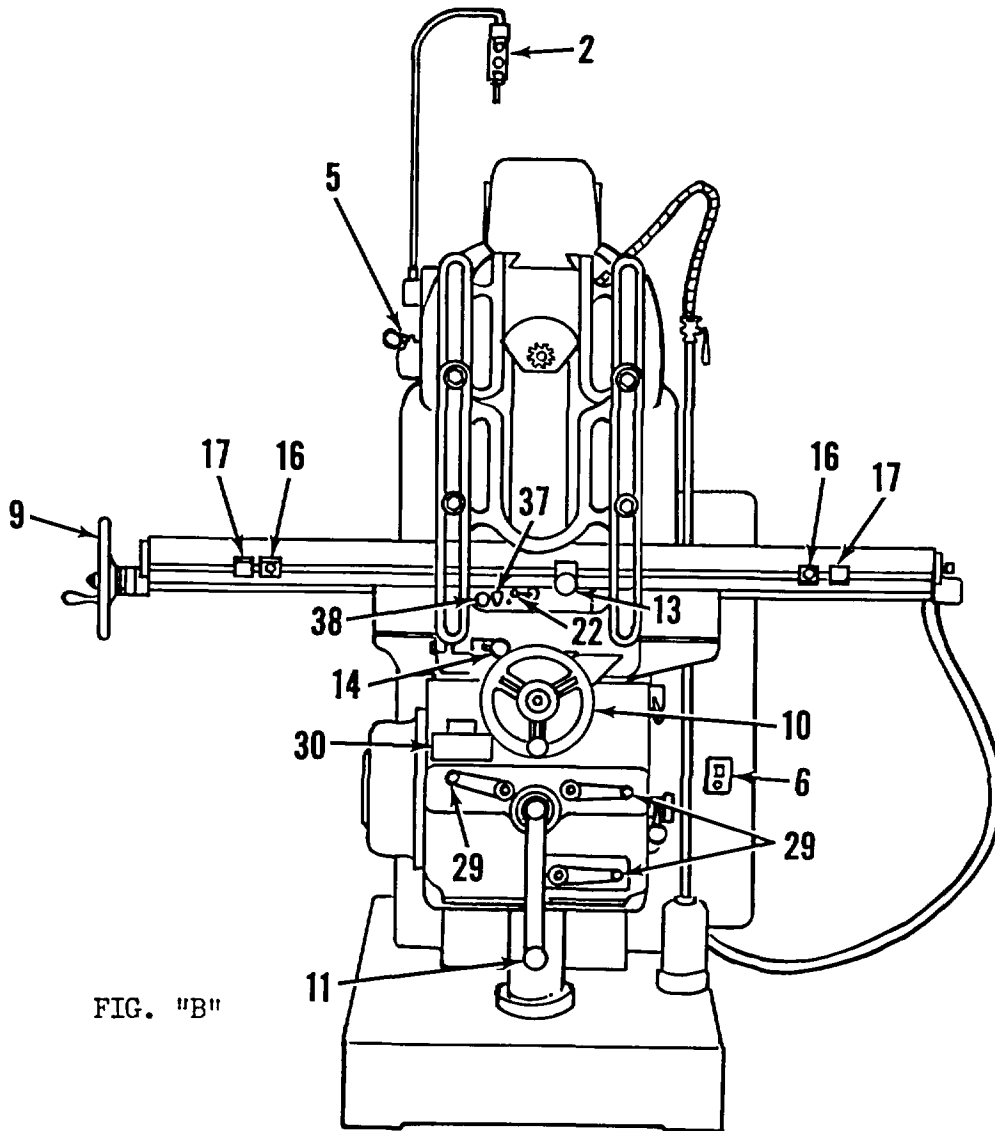

FIG. "B"

Figure B.

SECTION IV

MAINTENANCE- LUBRICATION

5. Knee

The knee contains the lubricating oil necessary for proper operation. All working parts are bathed in oil. The oil gauge window, (31, fig. A) shows the oil level. Do not allow the oil level to fall below this window. To add lubricant, remove the pipe plug (32) and insert a 90° street elbow in this tapped hole. Pour oil through a funnel into this elbow until the desired oil level is obtained.

Caution:

Unless the proper oil level is maintained an accelerating rate of oil loss could result. Provision is made for draining the oil when necessary. Remove the pipe plugs located on the bottom of the knee should it be necessary to drain the oil.

6. Column

Lubricating oil for the speed gearing is in the column. Do not allow the oil level to fall below the oil gauge window (33, fig. C). Another window, (34) is provided as an aid in determining if there is oil pressure. As long as the pump is operating a spray of oil is visible on the window. There are two pipe plugs on the shifter plate (35) and (36). The pipe plug (35) is provided for filling. Fill in the same manner as recommended for the knee. The pipe plug provided for draining is (36).

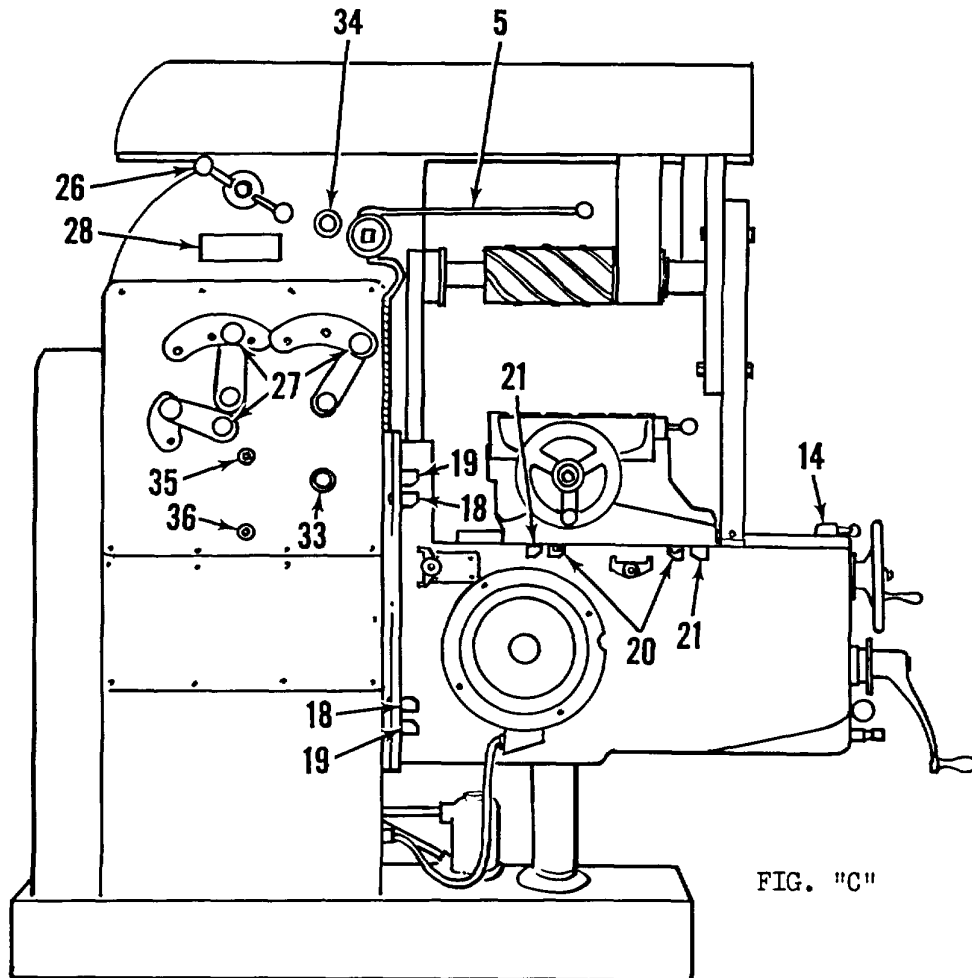

Figure C.

7. Saddle

An oil filler cup is provided on the saddle for filling the reservoir in the saddle (87, fig. B). It is extremely important that this reservoir is kept full. Check frequently to avoid operating difficulties. A "one-shot" oil plunger pump is located on the front of the saddle. All bearing surfaces on the knee, table, and saddle are lubricated by this device. Use this plunger pump once for every four hours of operation of the machine. The plunger pump is shown (38, fig. B). To operate this plunger, turn the knurled handle until the pin on the body is disengaged from the stationary part. Pull the knob out as far as it will go. Push the knob in and re-engage the pin.

8. Various

Filler cups are located at various positions on the machine. Oil these points at regular intervals. Also oil all machined and unpainted surfaces regularly. Clean and oil all ways and bearing surfaces daily. *DO NOT* use an air pressure nozzle for cleaning machine under any circumstances.

9. Gib Adjustment

The gibs in this machine are of the tapered style. They are held securely in position by means of a screw on each end. A certain amount of judgment, acquired through experience, is necessary to determine the correct slide movement, too tight an adjustment squeezes the oil film out of the ways and causes unnecessary wear and possible scoring. It is important, therefore, that only an experienced man be permitted to adjust the gibs. Procedure is as follows:

- a. Loosen screw at thin end of gib by turning in a counter clockwise direction.
- b. Turn screw at thick end of gib in a clockwise direction until movement of slide is tight.
- c. Turn screw at thick end of gib in a counter clockwise direction until slide is free to move without undue exertion.
- d. Turn screw at thin end of gib in a clockwise direction thereby locking the gib in position.

10. V-Belt Adjustment

A pivoted motor drive is employed for the main drive motor. It is located at the rear of the machine and the sheaves and belts are inclosed beneath a guard (39, fig. A). To adjust the belts remove this guard. The motor

base is pivoted and provided with a screw adjustment on the left side of the motor base to take up for wear or stretch in the belts.

a. *Overarm Handwheel and Clamps.* The overarm clamp is tightened by tightening the two nuts on the column (1, fig. A). When these are free, the overarm may be moved to the desired position by operating the handwheel (26) located at the top of the column. Always tighten the clamps when the overarm has been moved to the desired position.

b. *Spindle.* The spindle nose is the standard nonsticking taper which depends on the drawbar to hold the arbors in position. Arbors should be drawn in tight to avoid "run-out". Always wipe the taper of the arbor to remove chips or dirt before clamping the arbor in the spindle.

c. *Safety Clutch.* This machine is provided with a safety clutch to protect the gears, shafts, etc., in case the machine is overloaded. If you overload the machine, it will stop feeding and you will hear a "clicking" noise. This is the safety clutch operating. Shut off the machine immediately. After the cause of the overload has been corrected, the machine can be restarted without any further adjustment.

d. *Spindle Speeds.* The machine has 18 spindle speeds ranging from 25 to 1,250 rpm. The speed change levers are located on the top left side of the column as viewed when facing the machine. The speed plate is also located here. The speed change levers are depicted in (27, fig. C) and the speed plate is shown, as (28). *Do not shift these levers while the main drive motor is running.* First, set the spindle control switch (previously mentioned in the electric control section) at "stop" position. If the levers now do not readily shift into position, use the "jog" position of the spindle control switch to rotate the gears slightly, permitting them to slip into position. Place levers in positions indicated by the speed plate to obtain the desired speed.

e. *Feeds.* The machine has 18 feeds ranging from 1/2 inch per minute to 30 inches per minute. The feed change levers are located on the front of the knee as illustrated in (29), figure B. The feed plate (30) is also located here. *Do not attempt to shift gears while taking a cut.* To shift gears the knee feed motor should be running. Place all feed levers in neutral position before shifting. There are no other special instructions for obtaining desired feed rates *except when shifting to 30 inches per minute.* To shift to 30 inches per minute, place the "F.N.S." lever in "S" position. Then place the "Z.Y.X." lever in "X" position and the "6.5.4" lever in "5" position. Now, to obtain 30 inches per minute, shift the "F.N.S." lever from "S" position to "F" position.

f. Manual Controls.

g. Safety Handwheels and Crank. Two handwheels and one crank are provided to manually position the table longitudinally, in a cross direction and vertically. The longitudinal handwheel is located on the left end of the table as viewed when facing the machine (9, fig. B). The cross direction handwheel is located on the front of the knee (10). The vertical crank is located on the front of the knee (11, figs. A and B). These controls are engaged by pushing them into position against a slight spring resistance and slowly rotating them until the pins are engaged. When the pins are engaged, continue to exert a slight inward force while rotating the wheel or crank until the desired position is obtained.

h. Rapid Traverse Lever. The rapid traverse lever is located on the right side of the knee as viewed when facing the machine (12, fig. A). This lever actuates a clutch. To engage the clutch, pull the lever upward. With the lever held in this position, the machine will traverse rapidly when the knee feed motor is turned on and feed direction has been selected by positioning the desired feed directional control lever. To release the clutch, simply release the rapid traverse lever and the clutch will disengage bringing the rapid traverse motion to a stop.

i. Feed Directional Controls.

j. Longitudinal Directional Control. The longitudinal directional control is located on the front of the saddle (13, figs. A and B). From a neutral position, apply a light, steady pressure to this lever in the direction the table is to travel until clutch engages. For example; if, when facing the front of the machine, this lever is engaged to the right, the table will travel to the right.

k. Cross Directional Control. The cross directional control is located on top left portion of the knee toward the front of the machine (14, figs. B and C). From neutral position set this lever in the direction (toward or away from operator while facing the front of the machine) that the saddle and table are to travel.

l. Vertical Directional Control. The vertical directional control is located on the right side of the knee as viewed when facing the machine (15, fig. A). From neutral position set this lever in the direction (up or down) that the table saddle and knee are to travel.

m. Feed Direction Stops. The machine is provided with stops to limit the travel of the knee, saddle, and table in any direction by disengaging the feed and returning the control lever to a neutral position. Each directional limit has a pair of adjustable stops and a pair of dead stops. The adjustable stops may be set for any distance within the range of the dead stops. Dead stops are set at the factory and in no case should their limits be exceeded. The table adjustable stops are illustrated in (16), figure B, the table dead stops in (18), figure C, and vertical dead stops (19), figure C. Saddle adjustable stops (20) and saddle dead stops (21) are shown in figure C.

n. Clamps. Clamps are provided for the knee, saddle, and table. The table clamp is located on the front of the saddle (22), figure B. The saddle clamp is located on the side of the saddle (23), figure A. The knee is clamped in position by tightening the screws in the gib holder (24, fig. A). If your machine is a universal model, the swivel is clamped in position by tightening the screws on the underside of the saddle (25), figure A.

APPENDIX A
BASIC ISSUE ITEMS LIST

Section I. PREFACE

1. General

This appendix is a list of basic issue items. It is composed of those items which make up the major end item of equipment and the operator's tools and equipment that are issued with the equipment and are required for stockage.

2. Requisitioning a Part to Which FSN Has Not Been Assigned

When requisitioning a C source (local procurement) item identified only by a manufacturer's part number, it is mandatory that the following information be furnished the supply officer:

a. Manufacturer's code number (5 digit number preceding the colon in the descriptive column).

b. Manufacturer's part number (the number, and sometimes letters, following the colon, (a) above). Dashes, commas, or other marks must be included exactly as listed.

c. Nomenclature exactly as listed herein, including dimensions if necessary.

d. Name of manufacturer of end item (from cover of TAI or manufacturer's name plate).

e. Federal stock number of end item (from TM).

f. Manufacturer's model number (from TM or name/data plate, preferably name/data plate).

g. Manufacturer's serial number (from name/ data plate).

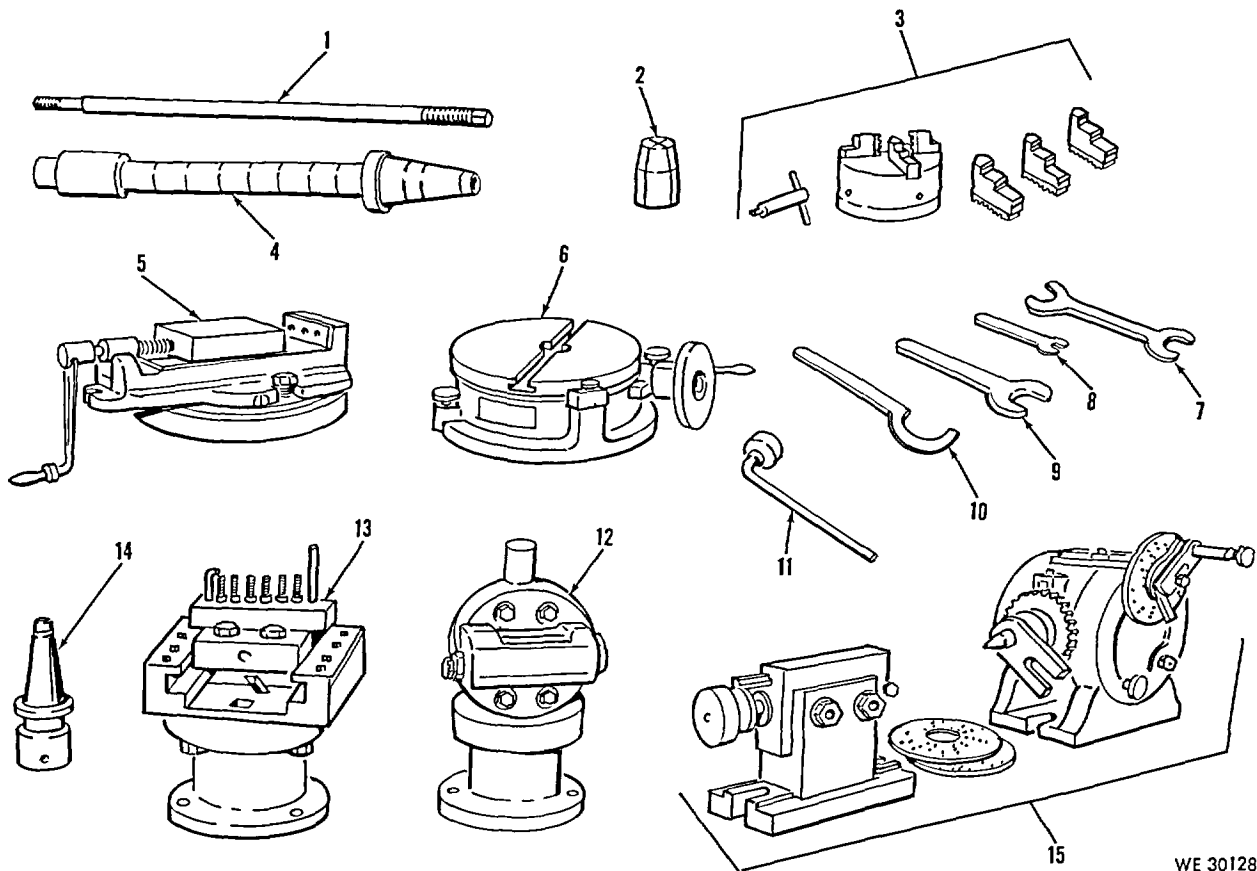

Figure D.

WE 30128

h. Any other information such as type, frame number, and electrical characteristics, if applicable.

i. If DD Form 1348 (DOD Single Line Item Requisition System Document) is used, fill in all blocks except 4, 5, 6, and remarks field, in accordance with AR 725-50. Complete form as follows:

- (1) In blocks 4, 5, and 6, list manufacturer's code and manufacturer's part number (as listed in description column).
- (2) In remarks field, list noun name (repair part), end item application (FSN of end item), manufacturer, model number (end item), serial number (end item), and any other pertinent information such as frame number, type, etc.

3. Explanation of Columns

a. *Source, Maintenance, and Recoverability Code (col. 1).*

- (1) *Materiel numerical codes (col. 1a).* This column is not required.
- (2) *Source (col. 1b).* This column indicates the selection status and source for the listed item. Source code used in this list is

<i>Code</i>	<i>Explanation</i>
C	Obtain through local procurement. If not obtainable from local procurement, requisition through normal supply channels with a supporting statement of nonavailability from local procurement.

- (3) *Maintenance level (col. 1c).* This column indicates the category of maintenance authorized to install the listed item. Maintenance level code used in this list is

<i>Code</i>	<i>Explanation</i>
O/C	Operator or crew maintenance

- (4) *Recoverability (col. 1d).* This column indicates whether unserviceable items should be returned for recovery or salvage. When no code is indicated, the item will be considered expendable. Recoverability code used in this list is

<i>Code</i>	<i>Explanation</i>
R	Items which are economically repairable at direct and general support maintenance activities and are normally furnished by supply on an exchange basis.

b. *Federal Stock Number (col. 2).* Self explanatory.

c. *Description (col. 3).* This column indicates the Federal item name (shown in capital letters) and any additional description required for supply operations: The manufacturer's code and part number are also included for reference.

<i>Code</i>	<i>Explanation</i>
26118	Greaves Machine Tool Div. of Fay & Egan Co.

d. *Unit of Issue (col. 4), Quantity Authorized (col. 5), and Illustrations (col. 6).* Self explanatory.

4. Abbreviations

<i>Abbreviations</i>	<i>Explanation</i>
c.....	cycle(s)
c/o.....	consists of
deg.....	degree(s)
med.....	medium
mtg.....	mounting
o/a.....	overall
ph.....	phase
rd.....	round
S.....	steel
sp.....	special
std.....	standard
w/.....	with
v.....	volt(s)

5. Errors, Comments, and/or Suggestions

Reports of errors, comments, and/or suggestions are encouraged. They should be submitted on DA Form 2028 (Recommended Changes to DA Publications) and forwarded direct to Commanding General, Headquarters, U.S. Army Weapons Command, ATTN: AMSWE-SMM-P, Rock Island Arsenal, Rock Island, Ill., 61201.

Section II. BASIC ISSUE ITEMS LIST

(1) Source, maintenance, and recoverability code				(2)	(3)	(4)	(5)	(6) Illustration	
(a)	(b)	(c)	(d)	Federal stock No.	Description	Unit of Issue	Quantity authorized	(a)	(b)
Materiel Code	Source	Maintenance level	Recoverability					Figure No.	Item No.
	R	3417-240-1303	<p align="center">MAJOR COMBINATION</p> <p>The following item is to be requisitioned for initial use only.</p> <p>MACHINE, HORIZONTAL, UNIVER- SAL: floor mtg, 49 x 10 working surface, 28 in. longitudinal travel, 10 in. cross travel, 16 1/2 in. vertical travel, 5 hp, 208-v, 60-c, 3-ph (Greaves Machine Tool Div. of Fay Egan Co. Models 2XH and 2H).</p> <p align="center">COMPONENTS OF MAJOR COMBINATION None authorized.</p> <p align="center">SPARE PARTS None authorized.</p> <p align="center">TOOLS AND EQUIPMENT FOR: MILLING MACHINE, HORIZONTAL, UNIVERSAL (26118:2XH and 2H).</p>				
	C	O/C	ADAPTER, CHUCK: collet, No. 50 taper (26118:55238).	ea	1	D	14
	C	O/C	R	ARBOR, SPINDLE: style A, No. 50 taper, 7/8 dia, 12 lg, 23/32 outboard bearing, w/spacers and arbor nut (26118:36127).	ea	1	D	
	C	O/C	R	ARBOR, SPINDLE: style A, No. 50 taper, 1 dia, 15 lg, 23/32 outboard bearing, w/spacers and arbor nut (26118:36130).	ea	1		
	C	O/C	R	ARBOR, SPINDLE: style B, No. 50 taper, 1 dia, 18 lg, w/spacers and arbor nut (26118:36162).	ea	1		
	C	O/C	R	ARBOR, SPINDLE: style B, No. 50 taper, 1 1/4 dia, 24 lg, w/spacers and arbor nut (26118:36166).	ea	1		
	C	O/C	R	ATTACHMENT, MILLING: universal, No. 40 taper (2618:113).	ea	1	D	12
	C	O/C	R	ATTACHMENT, SLOTTING. 0 to 4 stroke, uses std slotting tools 5/8 or 1 dia (26118:115).	ea	1	D	13
	C	O/C	R	CHUCK, MACHINE: 3-jaw, universal, 6 in., scroll type, w/internal and external jaws and wrench (26118:3684).	ea	1	D	3
	C	O/C	COLLET SET: spring type, rd hole grip, S, (26118:55165) c/o:	set	1		
	C	O/C	COLLET, MACHINE: 1/8 hole dia.	ea	1	D	2
	C	O/C	COLLET, MACHINE: 5/32 hole dia.	ea	1		
	C	O/C	COLLET, MACHINE: 3/16 hole dia.	ea	1		
	C	O/C	COLLET, MACHINE: 7/32 hole dia.	ea	1		
	C	O/C	COLLET, MACHINE: 1/4 hole dia.	ea	1		
	C	O/C	COLLET, MACHINE: 9/32 hole dia.	ea	1		
	C	O/C	COLLET, MACHINE: 5/16 hole dia.	ea	1		
	C	O/C	COLLET, MACHINE: 11/32 hole dia.	ea	1		
	C	O/C	COLLET, MACHINE: 3/8 hole dia.	ea	1		
	C	O/C	COLLET, MACHINE. 13/32 hole dia.	ea	1		
	C	O/C	COLLET, MACHINE: 7/16 hole dia.	ea	1		
	C	O/C	COLLET, MACHINE: 15/32 hole dia.	ea	1		
	C	O/C	COLLET, MACHINE: 1/2 hole dia.	ea	1		
	C	O/C	COLLET, MACHINE: 17/32 hole dia.	ea	1		

Section II. BASIC ISSUE ITEMS LIST (Continued)

(1) Source, maintenance, and recoverability code				(2) Federal stock No.	(3) Description	(4) Unit of Issue	(5) Quantity authorized	(6) Illustration	
(a) Materiel Code	(b) Source	(c) Maintenance level	(d) Recoverability					(a) Figure No.	(b) Item No.
					TOOLS AND EQUIPMENT FOR -Continued				
	C	O/C	COLLET, MACHINE: 9/16 hole dia.	ea	1		
	C	O/C	COLLET, MACHINE: 19/32 hole dia.	ea	1		
	C	O/C	COLLET, MACHINE: 5/8 hole dia.	ea	1		
	C	O/C	COLLET, MACHINE: 21/32 hole dia.	ea	1		
	C	O/C	COLLET, MACHINE: 11/16 to hole dia.	ea	1		
	C	O/C	COLLET, MACHINE: 3/4 hole dia.	ea	1		
	C	O/C	COLLET, MACHINE: 13/16 hole dia.	ea	1		
	C	O/C	COLLET, MACHINE: 7/8 hole dia.	ea	1		
	C	O/C	DRAWBAR, ADAPTER: collect (26118:680).	ea	1	D	1
	C	O/C	R	HEAD, DIVIDING: complete v/tailstock and spiral cutting mechanism (26118:DSR10).	ea	1	D	15
	C	O/C	NUT, LOCKING: drawbar (26118:146).	ea	1		
	C	O/C	R	TABLE, ROTARY: 12 in. dia, med-duty (26118:R-12).	ea	1	D	6
	C	O/C	R	VICE, TABLE: swivel, 6 in. jaw cap. (26118:1026).	ca	1	D	5
	C	O/C	5120-187-7134	WRENCH, OPEN END, FIXED: dble hd type, 1 1/16 and 1 1/4 wrench opngs, 15 deg angle of hd, hd thk 1/2 in., 11 3/4 lg o/a.	ea	1	D	7
	C	O/C	5120-277-1255	WRENCH, OPEN END, FIXED: sgle hd type, 25/32 wrench opng, 15 deg angle of hd, hd thk 7/16 in., 7 3/8 lg o/a.	ea	1	D	8
	C	O/C	5120-288-8702	WRENCH, OPEN END, FIXED: sgle hd type, 1 3/4 wrench opng, 15 deg, hd thk 5/16 in. 12 1/4 lg o/a.	ea	1	D	9
	C	O/C	5120-224-2535	WRENCH, SOCKET: sgle socket offset type, 90 deg offset hex socket, 1 1/4 wrench opng, 2 1/2 offset, 11 lg o/a.	ea	1	D	11
	C	O/C	WRENCH, SPANNER: collet adapter (26118:sp).	ea	1	D	10

By Order of the Secretary of the Army:

HAROLD K. JOHNSON,
General, United States Army,
Chief of Staff.

Official:

KENNETH G. WICKHAM,
Major General, United States Army,
The Adjutant General.

Distribution:

Active Army:

DCSLOG (1)
CNGB (1)
TSG (1)
CofEngrs (3)
CofSptS (2)
CofT (1)
USCONARC (3)
USAMC (3)
USASMCOM (3)
USAWECOM (75)
ARADCOM (2)
ARADCOM Rgn (2)
OS Maj Comd (3)
LOGCOMD (3)
USACDCEC (10)
Armies (3) except
 2d USA (2)
 7th USA (5)
 EUSA (5)

Corps (2)
USA Corps (2)
Fort Belvoir (2)
Fort Knox Fld Maint (10)
USAAVCOM (5)
Fld Maint Shops (2)
Army Dep (3)
Arsenals (2)
USASA 4th Fld Sta (1)
Units org under fol TOE:
 (2 copies each)
 11-15
 11-17
 11-38
 11-158
 11-587

NG: None.

USAR: None.

For explanation of abbreviations used, see AR 320-50.

RECOMMENDED CHANGES TO EQUIPMENT TECHNICAL PUBLICATIONS



THEN...JOT DOWN THE DOPE ABOUT IT ON THIS FORM. CAREFULLY TEAR IT OUT, FOLD IT AND DROP IT IN THE MAIL.

SOMETHING WRONG WITH PUBLICATION

FROM: (PRINT YOUR UNIT'S COMPLETE ADDRESS)

DATE SENT

PUBLICATION NUMBER

PUBLICATION DATE

PUBLICATION TITLE

BE EXACT PIN-POINT WHERE IT IS

PAGE NO.

PARA-GRAPH

FIGURE NO.

TABLE NO.

IN THIS SPACE, TELL WHAT IS WRONG AND WHAT SHOULD BE DONE ABOUT IT.

TEAR ALONG PERFORATED LINE

PRINTED NAME, GRADE OR TITLE AND TELEPHONE NUMBER

SIGN HERE

THE METRIC SYSTEM AND EQUIVALENTS

WEIGHT MEASURE

1 Centimeter = 10 Millimeters = 0.01 Meters = 0.3937 Inches
 1 Meter = 100 Centimeters = 1000 Millimeters = 39.37 Inches
 1 Kilometer = 1000 Meters = 0.621 Miles

WEIGHTS

1 Gram = 0.001 Kilograms = 1000 Milligrams = 0.035 Ounces
 1 Kilogram = 1000 Grams = 2.2 lb.
 1 Metric Ton = 1000 Kilograms = 1 Megagram = 1.1 Short Tons

LIQUID MEASURE

1 Milliliter = 0.001 Liters = 0.0338 Fluid Ounces
 1 Liter = 1000 Milliliters = 33.82 Fluid Ounces

SQUARE MEASURE

1 Sq. Centimeter = 100 Sq. Millimeters = 0.155 Sq. Inches
 1 Sq. Meter = 10,000 Sq. Centimeters = 10.76 Sq. Feet
 1 Sq. Kilometer = 1,000,000 Sq. Meters = 0.386 Sq. Miles

CUBIC MEASURE

1 Cu. Centimeter = 1000 Cu. Millimeters = 0.06 Cu. Inches
 1 Cu. Meter = 1,000,000 Cu. Centimeters = 35.31 Cu. Feet

TEMPERATURE

$5/9(^{\circ}\text{F} - 32) = ^{\circ}\text{C}$
 212° Fahrenheit is equivalent to 100° Celsius
 90° Fahrenheit is equivalent to 32.2° Celsius
 32° Fahrenheit is equivalent to 0° Celsius
 $9/5^{\circ}\text{C} + 32 = ^{\circ}\text{F}$

APPROXIMATE CONVERSION FACTORS

TO CHANGE	TO	MULTIPLY BY
Inches	Centimeters	2.540
Feet	Meters	0.305
Yards	Meters	0.914
Miles	Kilometers	1.609
Square Inches	Square Centimeters	6.451
Square Feet	Square Meters	0.093
Square Yards	Square Meters	0.836
Square Miles	Square Kilometers	2.590
Acres	Square Hectometers	0.405
Cubic Feet	Cubic Meters	0.028
Cubic Yards	Cubic Meters	0.765
Fluid Ounces	Milliliters	29.573
its	Liters	0.473
arts	Liters	0.946
allons	Liters	3.785
Ounces	Grams	28.349
Pounds	Kilograms	0.454
Short Tons	Metric Tons	0.907
Pound-Feet	Newton-Meters	1.356
Pounds per Square Inch	Kilopascals	6.895
Miles per Gallon	Kilometers per Liter	0.425
Miles per Hour	Kilometers per Hour	1.609

TO CHANGE	TO	MULTIPLY BY
Centimeters	Inches	0.394
Meters	Feet	3.280
Meters	Yards	1.094
Kilometers	Miles	0.621
Square Centimeters	Square Inches	0.155
Square Meters	Square Feet	10.764
Square Meters	Square Yards	1.196
Square Kilometers	Square Miles	0.386
Square Hectometers	Acres	2.471
Cubic Meters	Cubic Feet	35.315
Cubic Meters	Cubic Yards	1.308
Milliliters	Fluid Ounces	0.034
Liters	Pints	2.113
Liters	Quarts	1.057
ers	Gallons	0.264
ms	Ounces	0.035
ograms	Pounds	2.205
Metric Tons	Short Tons	1.102
Newton-Meters	Pounds-Feet	0.738
Kilopascals	Pounds per Square Inch	0.145
ometers per Liter	Miles per Gallon	2.354
ometers per Hour	Miles per Hour	0.621

